



Composite Sealing Washers

aerospace
climate control
electromechanical
filtration
fluid & gas handling
hydraulics
pneumatics
process control
sealing & shielding



ENGINEERING YOUR SUCCESS.

Warning - User responsibility

This document and other information from Parker Hannifin Corporation, its subsidiaries and authorized distributors provide product or system options for further investigation by users having technical expertise.

The user, through its own analysis and testing, is solely responsible for making the final selection of the system and components and assuring that all performance, endurance, maintenance, safety and warning requirements of the application are met. The user must analyze all aspects of the application, follow applicable industry standards, and follow the information concerning the product in the current product catalogue and in any materials provided from Parker or its subsidiaries or authorized distributors.

To the extent that Parker or its subsidiaries or authorized distributors provide component or system options based upon data or specifications provided by the user, the user is responsible for determining that such data and specifications are suitable and sufficient for all applications and responsibly foreseeable uses of the components or systems.

Range of Application

Our seals may only be used within the application parameters stated in our documents as regards compatibility with contact media, pressures, temperatures and time of storage. Application or use outside of the specified application parameters as well as the selection of different compounds by mistake may result in damage to life, the environment and/or equipment and facilities.

The information contained in our publications is based on know-how developed over decades of experience in the manufacturing and application of seals. Despite this experience, unknown factors arising out of the practical application of seals may considerably affect the overall applicability of this information in such a way that the recommendations provided herein are not to be considered generally binding.

The data for working pressure, working temperature, and surface speed stated in the columns represent maximum values and are interrelated. Under extreme working conditions it is recommended not to use all maximum values simultaneously.

For special requirements (pressure, temperature, speed, etc.) please contact our Consultancy Service, so that suitable materials and/or designs can be recommended.

Compatibility of Seals and Operating Media / Cleaning Agents

Due to the great diversity of operational parameters affecting fluidic devices and their impact on seals, it is absolutely imperative that manufacturers of these devices approve seals for functional and operational suitability under field conditions.

Furthermore, in view of the consistent increase of newly available media used as hydraulic oils, lubricants, and cleaning agents, special attention is invited to the aspect of compatibility with sealing elastomers currently in use.

Additives contained in base media in order to enhance certain functional characteristics may affect compatibility characteristics of sealing materials.

For this reason, it is imperative that any product equipped with our seals be tested for compatibility with operational media or cleaning agents ap-

proved or specified by you either at your plant or by means of field tests prior to any serial application.

We kindly ask you to comply with this notice since, as a manufacturer of seals, we are not in a position, as a matter of principle, to perform simulations regarding any and all conditions present in the final application nor of knowing the composition of the operational media and cleaning agents used.

Design modifications

We reserve the right to make design modifications without prior notification.

Prototypes and samples

Prototypes and samples are produced from experimental moulds. The subsequent series production may differ in production techniques from the prototype production unless specific agreement to the contrary was reached beforehand.

Delivery and services

The delivery guarantee (availability of moulds) for individual dimensions of our range of products is limited to a period of 7 years.

Damaged moulds, including standard items, can only be replaced in case of sufficient demand. Most of the dimensions stated in this catalogue are normally (but not as a matter of course) available ex stock.

For the production of smaller quantities, special compounds, and in case of special production procedures, we reserve the right of charging a pro-rated share of set-up costs.

All deliveries and services are subject to our terms.

Quality Systems

Our manufacturing sites are certified according to ISO 9001 resp. ISO/TS 16949.

Copyright

All rights reserved by Parker Hannifin Corporation. Extracts may only be taken with permission. Modification rights reserved.

Validity

This edition supersedes all prior documents.

Contents	
Composite sealing washers – Introduction	4
Materials and selection aids	7
Surface protection techniques	8
Technical data and dimensions	9

Reliable sealing of threaded connections

Parker's composite sealing washers perform two major functions. Firstly, they provide reliable sealing against various media (oils, coolants and gases) in technical components used in automotive and mechanical engineering, for example. Secondly, they consistently assure ideal compression conditions between the bolt and flange and thus prevent the destruction of the seal.

These versatile composite parts allow reliable sealing concepts to be achieved in a wide range of applications such as in air conditioning systems or gas regulators and fuel pumps. This makes composite sealing washers the preferred solution to quickly eliminate leakage problems on threaded connections.

What are composite sealing washers?

Parker composite sealing washers consist of a metallic carrier and a vulcanised elastomer sealing lip. Depending on the requirements profile, various metals and elastomers can be combined with each other.

The requirements profile determines the type of composite sealing washer to be used. The WO series, for example, is designed for sealing below the screw head whereas the WT series is particularly well suited for internal sealing of threads.

What are the advantages of composite sealing washers?

- A single component provides the groove and seal.
- Since the composite sealing washer is visible from the outside the presence of the seal can be visually checked.
- After installation the sealing lip is protected against external influences and internal, mechanical overloading.
- The self-centring option eliminates the need for readjustment.
- No seal groove is required in the flanges.
- Composite sealing washers deliver reliable and long service.

How do composite sealing washers work?

The metallic carrier of the composite sealing washer prevents compression of the elastomer element beyond its resilience limit. As a result, the initial axial pressure acting on the seal is limited within the primary force closure and the sealing effect can occur in the secondary force closure. Since the metal carrier limits the sealing element on the inner diameter the elastomer seal is pushed forwards and pressed against the screw shaft and the other areas. This provides effective, reliable sealing for vacuum and high-pressure applications.

Where are composite sealing washers used?

Composite sealing washers are increasingly used in a wide range of applications and markets such as automotive engineering, air conditioning technology, energy, oil and gas (EOG) and general industrials. They are exclusively used for static sealing of threaded connections. The effectiveness of elastomer sealing elements can far exceed the sealing effect of copper washers. Customers can choose between various elastomers and metals which can be combined with each other with respect to their media resistance, for example. Composite sealing washers allow quick and easy fitting and can be customised to suit specific requirements.

Application conditions

The plane surfaces to be sealed must be free of scratches and coarse machining marks. The recommended maximum surface roughness is less than R_{\max} 15 μm , the recommended average peak-to-valley height below R_z 6.3 μm . Parker composite sealing washers are suitable for applications up to an operating pressure of approx. 200 MPa (2000 bar). Depending on the elastomer material used, operating temperatures between -50 and +200 °C are possible. The bursting pressure depends on the seal geometry, dimensions and material selection.

Finite Elements Analysis

If desired by the customer, we subject composite sealing washers to a Finite Elements Analysis, which allows us to assess the required compression forces, deformations or material stress in the elastomer profile before manufacturing the product.

The drawing depicts a threaded connection with a composite sealing washer. Shown in detail is the stress distribution in the deformed sealing lip: the darker the colour the heavier the deformation. The red line depicts the contour of the sealing lip in the non-deformed state.

Schematic drawing of a threaded connection

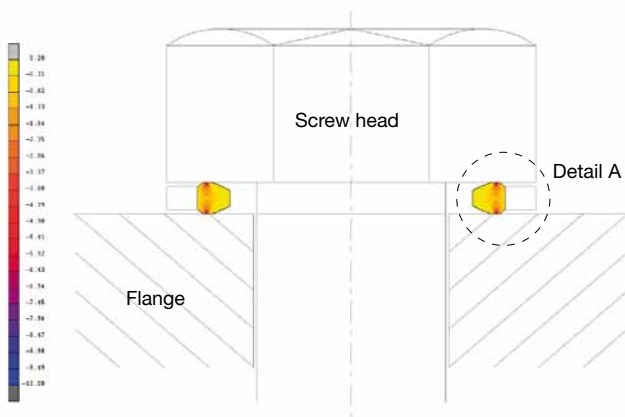

Detail A: composite sealing washer

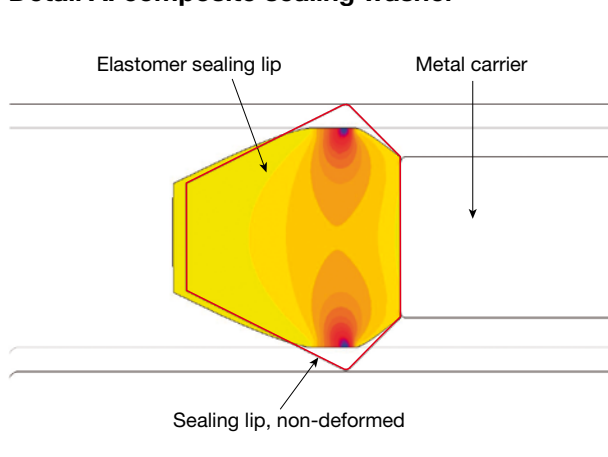

Composite sealing washers – Introduction

Design principle and types

Parker composite sealing washers consist of an elastomer sealing element which is chemically or mechanically bonded to a metallic carrier (washer). The metallic carrier prevents compression of the elastomer seal beyond its resilience limit and thus its destruction. It provides the groove for the elastomer part and transfers the torque through the primary force closure.

WX composite sealing washer



Parker WX series composite sealing washers have been designed to replace copper washers in high-pressure systems. The WX composite sealing washer is a time-tested and low-cost solution for screw head and flange sealing areas. The elastomer sealing lip is chemically bonded to the metal carrier.

WZ Composite sealing washer



Parker WZ series composite sealing washers are a further development of the WX series. They have an additional self-centring function on the inner diameter.

WO Composite sealing washer



Parker WO series composite sealing washers are designed for radial sealing below the screw head in the area of the smooth (non-threaded) screw shaft. This provides three functionally relevant sealing areas. The elastomer sealing lip is chemically and mechanically connected to the metal carrier.

WT Composite sealing washer



Parker WT series composite sealing washers have a circular seal geometry similar to the WO series. In addition, they have a self-centring function designed specifically for engaging the thread. The elastomer sealing lip is chemically and mechanically connected to the metal carrier.

Additional designs are available for special fastening applications. Please contact our consultancy service who will adapt the material and design to suit your specific application.

Elastomers

Acryl nitrile butadien rubber (NBR)

NBR exhibits good resistance to petrol and mineral oils, possesses high abrasion resistance and can be used at operating temperatures between -30 and +100 °C. NBR is the most commonly used polymer in the sealing industry.

Hydrogenated acryl nitrile butadien rubber (HNBR)

HNBR has a similar properties profile as NBR materials but better ozone resistance and suitability for temperatures of up to +150 °C. HNBR exhibits good resistance to oils and greases plus good wear resistance. HNBR is frequently used with central hydraulics fluids.

Fluoroelastomers (FKM)

FKM materials possess outstanding temperature and chemical resistance as well as exhibiting outstanding ozone, weather and age resistance. They may be used at temperatures of up to +200 °C (and higher for short-term exposure).

Ethylen propylene dien momomers (EPDM)

EPDM materials offer good ozone and weather resistance but are not resistant to mineral oil products. They are well suited for use with phosphate ester based hydraulic fluids, glycol based brake fluids and hot water as well as steam. EPDM are frequently used in conjunction with foodstuffs and in pneumatics.

For further materials, please enquire.

Carrier materials

Structural steel, e.g. 1.0330 (DC01, St12)

Structural steel possesses sufficient tensile strength for composite sealing washers. This version corresponds to the standard one and is heavy-build passivated for corrosion protection.

Quenched and tempered steel, e.g. 1.0503 (C45)

This steel exhibits high strength, tenacity and tensile strength. Quenched and tempered steel withstands even extreme loads and sudden shocks. Corrosion protection is also achieved through heavy-build passivation.

Aluminium, e.g. 3.3536 (AlMg3)

This aluminium alloy has relatively high strength and tenacity even at low temperatures plus good sea water and weather resistance.

Stainless steel, e.g. 1.4301 (V2A)

High-grade version using stainless steels which do not exhibit corrosion even in case of damage to the surface. Very good chemical resistance to various media.

For further materials, please enquire.

Hydraulic pressure fluid		Elastomer type			
		NBR -30 °C / +100 °C	HNBR -20 °C / +150 °C	FKM -20 °C / +200 °C	EPDM -50 °C / +150 °C
Mineral oil	H, HL, HLP, HVLP	+	+	+	-
Poly- α -olefins	PAO	+	+	+	-
Synthetic hydrocarbons	HEPR	+	+	+	-
Polyalkylenglycols	HEPG	+*)	+*)	(P) + / (B) -	+**)
Triglycerids	HETG	+	+	+	-
Synthetic esters	HEES	+*)	+*)	+	-
Brake fluid	DOT-3 / -4	-	-	-*)	+
Oil/water emulsion	HFAE HFAS, HFB	+	+	+	-
Water/glycol	HFC	+	+	+*)	-*)
Phosphoric acid esters	HFD	-	-	+	-*)

*) With limitations.

**) absolutely mineral oil free

(P) peroxidically crosslinked materials

(B) bisphenolically crosslinked materials

(H) hydrolysis stabilised versions

Surface protection techniques



Bare metal surfaces must be protected against corrosion and prepared for the elastomer vulcanisation. Typically, the metal surface is corrosively closed by a passivation technique and prepared for the subsequent vulcanisation of the elastomer sealing lip by means of a special phosphate coating.

Phosphating (bondering)

Phosphating is an anorganic process according to DIN 50942 and offers only limited corrosion protection. During the phosphating process a low-soluble metal phosphate coating is deposited on a metallic substrate.

Yellow chromate conversion coating

This technique became widely used due to its outstanding corrosion protection and economy. However, the coating contains hazardous chromium (VI) and has been prohibited since the publication of the EU End-of-Life Vehicles Directive (Directive 2000/E53/EC) and the restrictions of certain hazardous substances in electrical and electronics equipment (Directive 2002/95/EG).

Thick layer passivation

During the thick layer passivation process a chromitising solution is applied on top of the zinc alloy. The zinc surface chemically reacts with this solution and is converted into a chromitising coat. It offers particularly high corrosion protection and is now often used instead of yellow chromate conversion coating.

Blue chromate coating (passivation)

Zinc-coating followed by chromate coating is a method that has been successfully used with connecting elements due to its corrosion resistance as well as for visual reasons. The typical thickness of the coating is 5 µm. However, there may be a risk of hydrogen embrittlement (see below).

Testing of the surface protection

The salt spray test is a testing procedure standardized according to DIN EN ISO 9227 to determine the corrosion protection of coatings.

A saline solution (PH-value 6.5 to 7.2) is sprayed inside a chamber (min. volume 400 litres) at 35 °C or 50 °C chamber temperature. The NaCl solution can be mixed with acetic acid and copper chloride to intensify the effective mechanisms during the process that induces the corrosion.

The fine salt fog deposits on the samples and causes them to corrode. The quality of the coating is determined by the duration for which the samples withstand this medium without forming white rust (destruction of the chromium coating) or even red rust (basic metal corrosion). The samples are visually evaluated.

Process group	Nominal thickness (µm)	First appearance of	
		White rust (hrs.)	Red rust (hrs.)
Thin-film phosphating	1 – 3	4	12
Blue chromate coating	8	96	240
Thick layer passivation	8	168	360

The stated values are provided as guidelines only and depend on the particular component.

Hydrogen embrittlement

Electroplated composite sealing washers made of steels with tensile strengths of ≥ 1000 N/mm² (e.g. 8.8 to 12.9) and hardened parts with hardnesses of approx. 320 HV and higher, which are subjected to tensile stress, harbour the risk of failure due to hydrogen embrittlement. A heat treatment (tempering) of the parts, for instance after metal plating, reduces the risk of breaking. A complete elimination of the hydrogen embrittlement risk cannot be guaranteed. Alternative coating techniques may have to be used.

Composite sealing washers – Technical data and dimensions

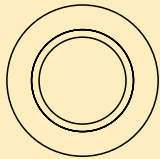
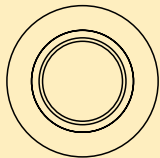
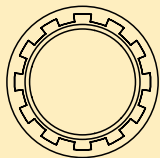
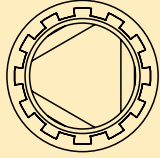
Top view	Profile reference	Page
Composite sealing washers		
	WX	10
	WZ	12
	WO	14
	WT	16

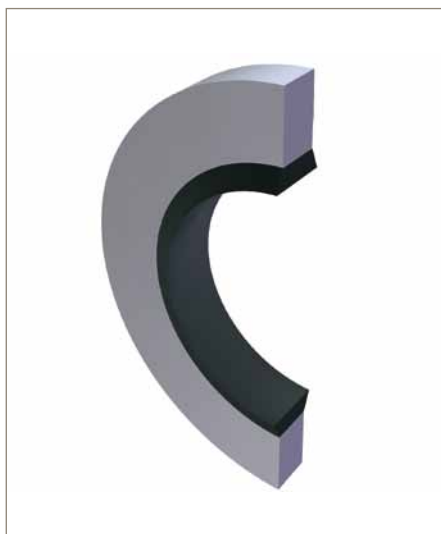

The Parker WX composite sealing washer consists of a metal washer with a rectangular cross-section and an elastomer sealing lip with a trapezoidal cross-section that is vulcanised to the inside.

The seal has been designed for use in high-pressure applications and can far exceed the sealing effect of copper washers or similar metal seals.

Range of application

Static sealing of flanges or screw heads.

Operating pressure	≤ 1500 bar
Operating temperature	
Z5170	-30 °C to +100 °C
Z5171	-20 °C to +150 °C
Z5172	-20 °C to +200 °C
Z5173	-50 °C to +150 °C

Compounds

Metal carrier made of steel 1.0330, heavy-build passivated.

The following standard materials are available for the elastomer sealing lip: NBR (Z5170), HNBR (Z5171), FKM (Z5172), EPDM (Z5173).

For special media such as HFO 1234yf elastomer materials with special approvals are available.

In case of special operating conditions please contact our consultancy service for a selection of the material and design best suiting your particular application requirements

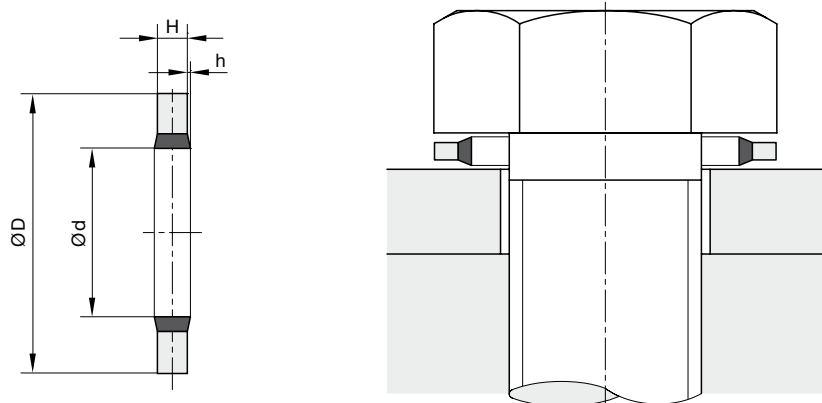

Metric dimensions

Thread	D (mm)	d (mm)	H (mm)	h (mm)	Bursting pressure (bar)	Ordering No.
M 4	7	4.5	1.0	0.3	1250	WX 0407 Z5170
M 5	10	5.7	1.0	0.3	1500	WX 0510 Z5170
M 6	10	6.7	1.0	0.3	1510	WX 0610 Z5170
M 8	13	8.7	1.0	0.3	1550	WX 0813 Z5170
M 10	16	10.7	1.5	0.4	1350	WX 1016 Z5170
M 12	18	12.7	1.5	0.4	1250	WX 1218 Z5170
M 14	22	14.7	1.5	0.4	1510	WX 1422 Z5170
M 16	24	16.7	1.5	0.4	1400	WX 1624 Z5170
M 18	26	18.7	1.5	0.4	1275	WX 1826 Z5170
M 20	28	20.7	1.5	0.4	1150	WX 2028 Z5170
M 24	32	24.7	2.0	0.4	1050	WX 2432 Z5170
M 26	35	26.7	2.0	0.4	1050	WX 2635 Z5170
M 30	39	31.0	2.0	0.4	860	WX 3039 Z5170

Imperial dimensions

BSP	Bolt	D (inch)	d (inch)	H (inch)	h (inch)	Bursting pressure (PSI)	Ordering No.
1/8	3/8	0.625	0.408	0.080	0.010	21750	WX 0316 Z5170
1/4	1/2	0.810	0.541	0.080	0.010	22480	WX 0621 Z5170
3/8	-	0.937	0.680	0.080	0.010	18275	WX 1024 Z5170
1/2	13/16	1.125	0.848	0.098	0.010	16680	WX 1329 Z5170
5/8	7/8	1.250	0.925	0.098	0.010	18130	WX 1623 Z5170
3/4	1	1.375	1.065	0.098	0.010	15375	WX 1935 Z5170
1	1 5/16	1.685	1.334	0.098	0.010	11750	WX 2543 Z5170
7/8	1 3/16	1.500	1.213	0.098	0.010	13055	WX 2238 Z5170
1 1/4	1 5/8	2.062	1.690	0.098	0.010	10010	WX 3252 Z5170
1 1/2	1 7/8	2.307	1.907	0.098	0.010	10010	WX 3859 Z5170
1 3/4	2 1/8	2.750	2.161	0.133	0.010	13780	WX 4470 Z5170
2	-	2.875	2.385	0.098	0.010	10150	WX 5173 Z5170
2 1/2	-	3.550	2.995	0.133	0.010	9865	WX 6490 Z5170

Further sizes on request.



The Parker WZ composite sealing washer consists of a metal washer with a rectangular cross-section and an elastomer sealing lip with a trapezoidal cross-section that is vulcanised to the inside. It is a further development of the WX series and has an additional self-centring function.

The seal has been designed for use in high-pressure applications and can far exceed the sealing effect of copper washers or similar metal seals.

Range of application

Static sealing of flanges or screw heads.

Operating pressure	≤ 1500 bar
Operating temperature	
Z5170	-30 °C to +100 °C
Z5171	-20 °C to +150 °C
Z5172	-20 °C to +200 °C
Z5173	-50 °C to +150 °C

Compounds

Metal carriers made of steel 1.0330, heavy-build passivated.

The following standard materials are available for the elastomer sealing lip: NBR (Z5170), HNBR (Z5171), FKM (Z5172), EPDM (Z5173).

For special media such as HFO 1234yf elastomer materials with special approvals are available.

In case of special operating conditions please contact our consultancy service for a selection of the material and design best suiting your particular application requirements

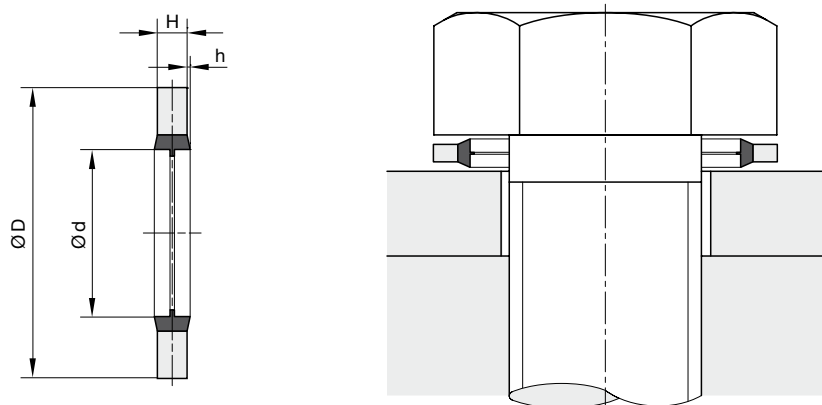

Metric dimensions

Thread	D (mm)	d (mm)	H (mm)	h (mm)	Bursting pressure (bar)	Ordering No.
M 4	7	4.5	1.0	0.3	1250	WZ 0407 Z5170
M 5	10	5.7	1.0	0.3	1500	WZ 0510 Z5170
M 6	10	6.7	1.0	0.3	1510	WZ 0610 Z5170
M 8	13	8.7	1.0	0.3	1550	WZ 0813 Z5170
M 10	16	10.7	1.5	0.4	1350	WZ 1016 Z5170
M 12	18	12.7	1.5	0.4	1250	WZ 1218 Z5170
M 14	22	14.7	1.5	0.4	1510	WZ 1422 Z5170
M 16	24	16.7	1.5	0.4	1400	WZ 1624 Z5170
M 18	26	18.7	1.5	0.4	1275	WZ 1826 Z5170
M 20	28	20.7	1.5	0.4	1150	WZ 2028 Z5170
M 24	32	24.7	2.0	0.4	1050	WZ 2432 Z5170
M 26	35	26.7	2.0	0.4	1050	WZ 2635 Z5170
M 30	39	31.0	2.0	0.4	860	WZ 3039 Z5170

Imperial dimensions

BSP	Bolt	D (inch)	d (inch)	H (inch)	h (inch)	Bursting pressure (PSI)	Ordering No.
1/8	3/8	0.625	0.408	0.080	0.010	21750	WZ 0316 Z5170
1/4	1/2	0.810	0.541	0.080	0.010	22480	WZ 0621 Z5170
3/8	-	0.937	0.680	0.080	0.010	18275	WZ 1024 Z5170
1/2	13/16	1.125	0.848	0.098	0.010	16680	WZ 1329 Z5170
5/8	7/8	1.250	0.925	0.098	0.010	18130	WZ 1623 Z5170
3/4	1	1.375	1.065	0.098	0.010	15375	WZ 1935 Z5170
1	1 5/16	1.685	1.334	0.098	0.010	11750	WZ 2543 Z5170
7/8	1 3/16	1.500	1.213	0.098	0.010	13055	WZ 2238 Z5170
1 1/4	1 5/8	2.062	1.690	0.098	0.010	10010	WZ 3252 Z5170
1 1/2	1 7/8	2.307	1.907	0.098	0.010	10010	WZ 3859 Z5170
1 3/4	2 1/8	2.750	2.161	0.133	0.010	13780	WZ 4470 Z5170
2	-	2.875	2.385	0.098	0.010	10150	WZ 5173 Z5170
2 1/2	-	3.550	2.995	0.133	0.010	9865	WZ 6490 Z5170

Further sizes on request.



The Parker WO composite sealing washer consists of a metal washer and a circular elastomer sealing lip with an additional mechanical connection to the inside edge of the supporting washer. The serrations achieve a positive connection of the elastomer with the supporting washer and the phenomenon of sheared sealing lips which is frequently encountered with composite sealing washers is prevented.

WO composite sealing washers are very robust in assembly and are suitable for sealing requirements below the screw head in the area of the smooth (non-threaded) screw shaft.

Range of application

Static sealing of flanges or screw heads.

Operating pressure	≤ 1500 bar
Operating temperature	
Z5170	-30 °C to +100 °C
Z5171	-20 °C to +150 °C
Z5172	-20 °C to +200 °C
Z5173	-50 °C to +150 °C

Compounds

Metal carriers made of steel 1.0330, heavy-build passivated.

The following standard materials are available for the elastomer sealing lip: NBR (Z5170), HNBR (Z5171), FKM (Z5172), EPDM (Z5173).

For special media such as HFO 1234yf elastomer materials with special approvals are available.

In case of special operating conditions please contact our consultancy service for a selection of the material and design best suiting your particular application requirements

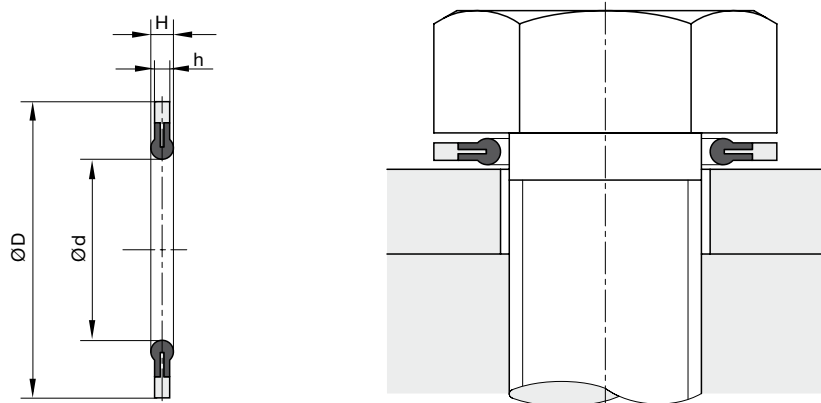

Metric dimensions

Screw Ø (mm)	D (mm)	d (mm)	H (mm)	h (mm)	Bursting pressure (bar)	Ordering No.
5	9.78	4.83	1.32	1.02	1050	WO 0510 Z5170
6	11.25	5.79	1.68	1.27	885	WO 0611 Z5170
8	13.49	7.77	1.68	1.27	545	WO 0813 Z5170
10	15.32	9.73	1.68	1.27	495	WO 1015 Z5170
12	19.30	11.71	1.68	1.27	490	WO 1219 Z5170
14	22.35	13.67	1.68	1.27	550	WO 1422 Z5170
16	27.10	15.67	1.68	1.27	860	WO 1627 Z5170
20	33.38	19.66	2.44	1.63	790	WO 2033 Z5170
22	31.50	21.62	1.68	1.27	300	WO 2232 Z5170

Imperial dimensions

Screw Ø (inch)	D (inch)	d (inch)	H (inch)	h (inch)	Bursting pressure (PSI)	Ordering No.
#6	0.385	0.130	0.050	0.040	20000	WO 0610 Z5170
#8	0.385	0.156	0.050	0.040	14900	WO 0810 Z5170
#10	0.443	0.180	0.072	0.050	11500	WO 1011 Z5170
1/4	0.505	0.240	0.072	0.050	9500	WO 0013 Z5170
5/16	0.603	0.301	0.072	0.050	6800	WO 0015 Z5170
3/8	0.666	0.364	0.072	0.050	6400	WO 0017 Z5170
7/16	0.760	0.427	0.072	0.050	6800	WO 0019 Z5170
1/2	0.880	0.490	0.072	0.050	7900	WO 0122 Z5170
9/16	1.067	0.552	0.072	0.050	12400	WO 0127 Z5170
5/8	1.193	0.615	0.072	0.050	14100	WO 0130 Z5170
3/4	1.322	0.740	0.096	0.064	10600	WO 0134 Z5170
7/8	1.510	0.864	0.096	0.064	11300	WO 0138 Z5170
1	1.760	0.988	0.096	0.064	13250	WO 0145 Z5170



The Parker WT composite sealing washer consists of a metal washer and a rectangular elastomer sealing lip with an additional mechanical connection to the inside edge of the supporting washer. The serrations achieve a positive connection of the elastomer with the supporting washer and the phenomenon of sheared sealing lips which is frequently encountered with composite sealing washers is prevented.

WT composite sealing washers ensure reliable sealing of screws in the threaded area. Assembly is self-centring and directionally independent.

Range of application

Static sealing of flanges or screw heads.

Operating pressure	≤ 1500 bar
Operating temperature	
Z5170	-30 °C to +100 °C
Z5171	-20 °C to +150 °C
Z5172	-20 °C to +200 °C
Z5173	-50 °C to +150 °C

Compounds

Metal carriers made of steel 1.0330, heavy-build passivated.

The following standard materials are available for the elastomer sealing lip: NBR (Z5170), HNBR (Z5171), FKM (Z5172), EPDM (Z5173).

For special media such as HFO 1234yf elastomer materials with special approvals are available.

In case of special operating conditions please contact our consultancy service for a selection of the material and design best suiting your particular application requirements

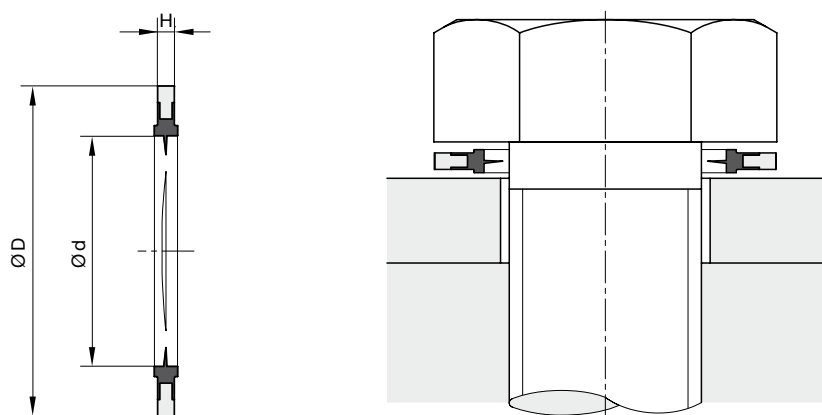

Imperial dimensions

Screw Ø (inch)	D (inch)	d (inch)	H (inch)	Bursting pressure (PSI)	Ordering No.
#6	0.406	0.141	0.050	1000	WT 0310 Z5170
#8	0.406	0.167	0.050	1000	WT 0410 Z5170
#10	0.469	0.194	0.050	1000	WT 0512 Z5170
#12	0.562	0.220	0.050	1000	WT 0514 Z5170
1/4	0.562	0.255	0.050	3000	WT 0614 Z5170
5/16	0.687	0.319	0.064	3000	WT 0817 Z5170
3/8	0.750	0.383	0.064	3000	WT 1019 Z5170
7/16	0.906	0.447	0.078	3000	WT 1123 Z5170
1/2	1.000	0.510	0.078	3000	WT 1325 Z5170
9/16	1.094	0.574	0.094	3000	WT 1428 Z5170
5/8	1.187	0.638	0.094	3000	WT 5170 Z5170
3/4	1.375	0.765	0.109	3000	WT 1935 Z5170
7/8	1.562	0.893	0.109	3000	WT 2240 Z5170
1	1.750	0.102	0.120	3000	WT 2544 Z5170

Notes

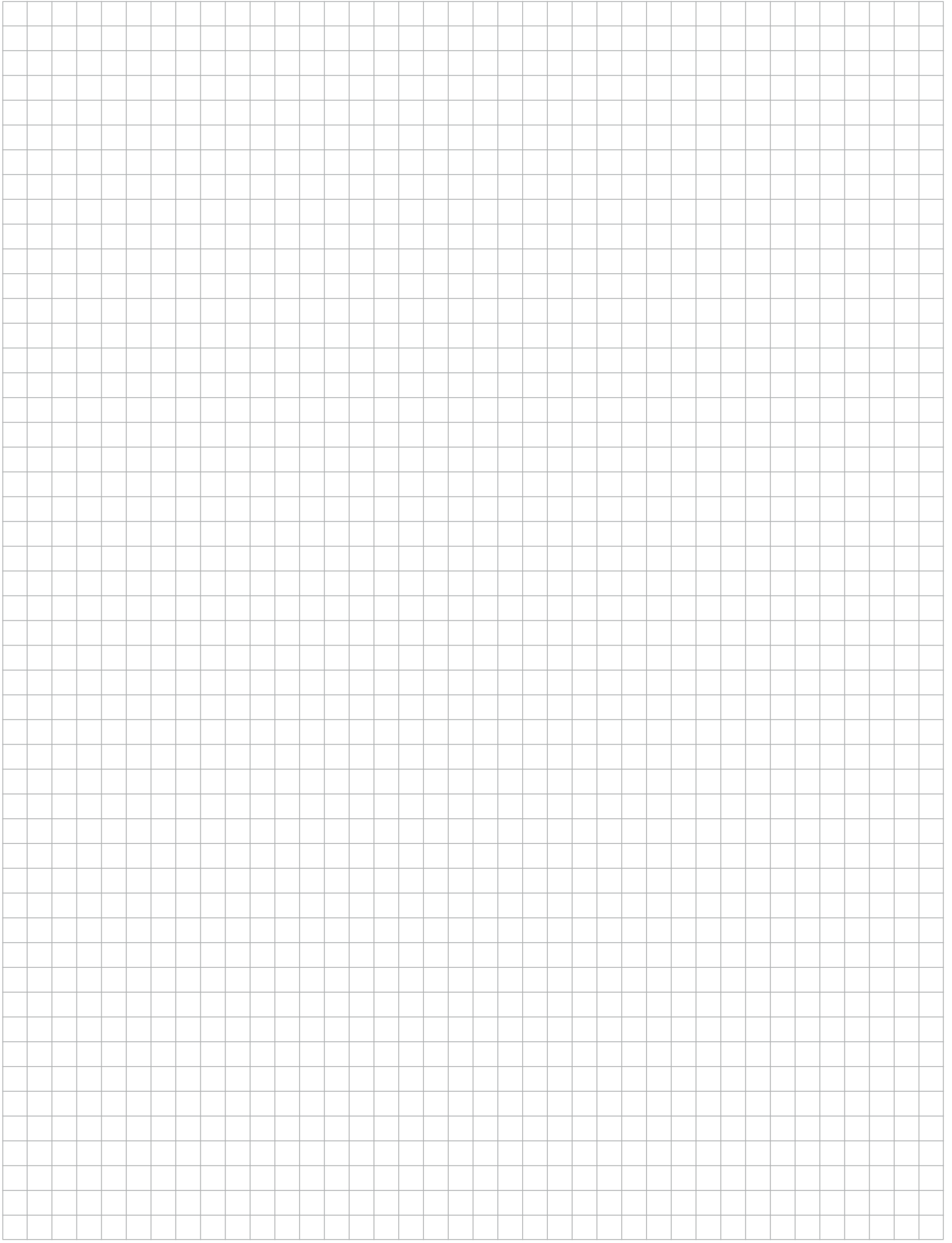

Parker-Prädifa Worldwide

AE – United Arab Emirates,
Dubai
Tel: +971 4 8127100
parker.me@parker.com

AR – Argentina, Buenos Aires
Tel: +54 3327 44 4129

AT – Austria, Wiener Neudorf
Tel: +43 2622 23501-0
parker.austria@parker.com

AU – Australia, Castle Hill
Tel: +61 2 9634 7777

AZ – Azerbaijan, Baku
Tel: +994 50 2233 458
parker.azerbaijan@parker.com

BE – Belgium, Boom
Tel: +32 3 880 81 50

BR – Brazil, Sao Paulo / SP
Tel: +55 11 39 15 8500

BY – Belarus, Minsk
Tel: +375 17 209 9399
parker.belarus@parker.com

CA – Canada, Milton, Ontario
Tel: +1 905 693 3000

CH – Switzerland, Etoy
Tel: +41 21 821 8700
parker.switzerland@parker.com

CL – Chile, Santiago
Tel: +56 2 623 1216

CN – China, Shanghai
Tel: +86 21 2899 5000

CZ – Czech Republic,
Klecany
Tel: +420 284 083 111
parker.czechrepublic@parker.com

DE – Germany,
Bietigheim-Bissingen
Tel: +49 7142 351 0

DK – Denmark, Espergaerde
Tel: +45 49 12 17 00

ES – Spain, Madrid
Tel: +34 91 6 75 73 00

ES – Spain, Barcelona
Tel: +34 93 6 35 51 73

FI – Finland, Vantaa
Tel: +358 20 753 2500
parker.finland@parker.com

FR – France,
Annemasse-Cédex
Tel: +33 4 50 87 80 80

GR – Greece
K Stamatiadis - E. Amlianitis
S.A., Athen
Tel: +30 10 5 15 11 11

HK – Hong Kong
Tel: +852 2428 8008

HU – Hungary, Budapest
Tel: +36 1 220 4155
parker.hungary@parker.com

IE – Ireland, Dublin
Tel: +353 1 466 6370
parker.ireland@parker.com

IN – India, Mumbai
Tel: +91 22 6513 7081-85

IT – Italy, Corsico (MI)
Tel: +39 02 45 19 21
parker.italy@parker.com

JP – Japan, Tokyo
Tel: +81 3 6408 3901

KR – Korea, Seoul
Tel: +82 2 559 0400

KZ – Kazakhstan, Almaty
Tel: +7 7272 505 800
parker.easteurope@parker.com

L – Luxembourg, Friederich-
Hydropart S.A.R.L., Schifflange
Tel: +352 54 52 44

MX – Mexico, Apodaca
Tel: +52 81 8156 6000

MY – Malaysia, Subang Jaya
Tel: +60 3 7849 0800

NL – Netherlands, Oldenzaal
Tel: +31 541 585 000
parker.nl@parker.com

NL – Netherlands
B. V. Profiltru, Almere
Tel: +31 36 53 2 42 28

NO – Norway
Norwegian Seals AS, Kleppe
Tel: +47 51 78 60 30

NO – Norway, Asker
Tel: +47 66 75 34 00
parker.norway@parker.com

NZ – New Zealand,
Mt Wellington
Tel: +64 9 574 1744

PL – Poland, Warsaw
Tel: +48 22 573 24 00
parker.poland@parker.com

PT – Portugal, Leca da Palmeira
Tel: +351 22 999 7360
parker.portugal@parker.com

RO – Romania, Bucharest
Tel: +40 21 252 1382
parker.romania@parker.com

RU – Russia, Moscow
Tel: +7 495 645 2156
parker.russia@parker.com

SE – Sweden, Spånga
Tel: +46 8 59 79 50 00
parker.sweden@parker.com

SG – Singapore
Tel: +65 6887 6300

SK – Slovakia, Banská Bystrica
Tel: +421 484 162 252
parker.slovakia@parker.com

SL – Slovenia, Novo Mesto
Tel: +386 7 337 6650
parker.slovenia@parker.com

TH – Thailand, Bangkok
Tel: +662 186 7000-99

TR – Turkey, Istanbul
Tel: +90 216 4997081
parker.turkey@parker.com

TW – Taiwan, Taipei
Tel: +886 2 2298 8987

UA – Ukraine, Kiev
Tel: +380 44 494 2731
parker.ukraine@parker.com

UK – United Kingdom, Glasgow
Tel: +44 141 302 5000

US – USA, Cleveland
Tel: +1 216 896 3000

VE – Venezuela, Caracas
Tel: +58 212 238 5422

ZA – South Africa,
Kempton Park
Tel: +27 11 961 0700
parker.southafrica@parker.com